

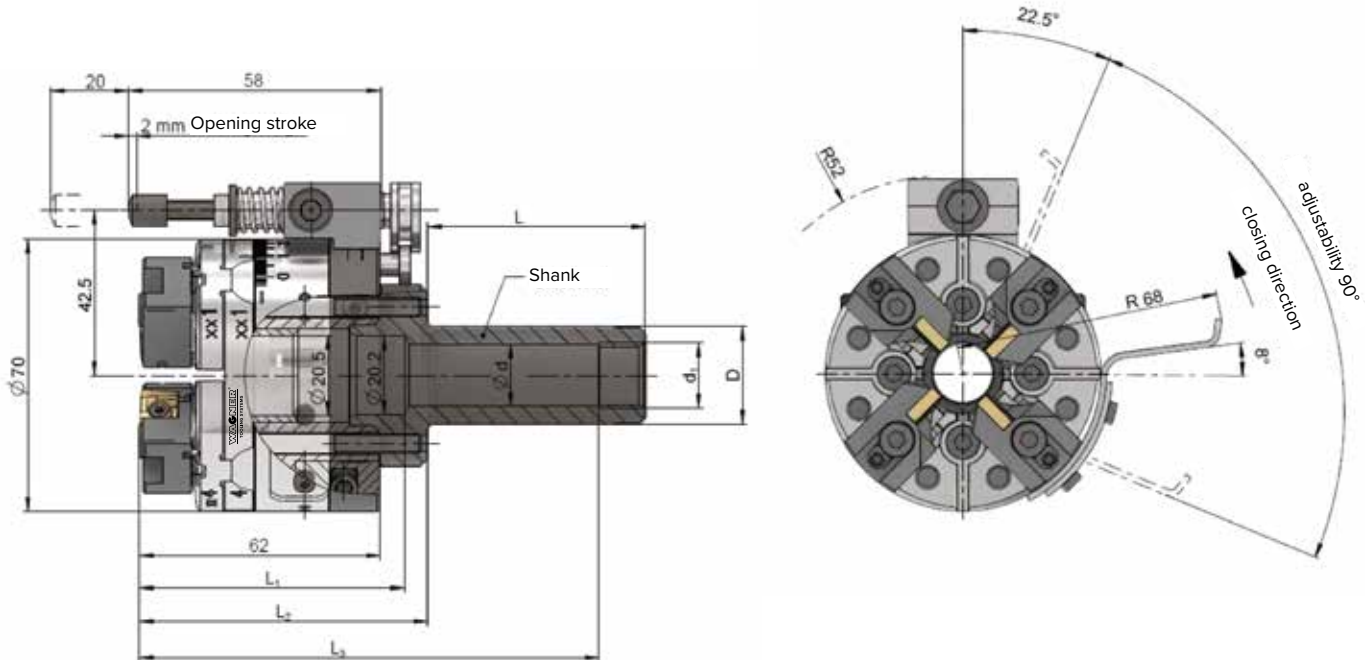

Multi-cutter Turning System MSD20



Insert holders	Cutting inserts	Cutting edge position	Working range
W01 B5	Wagner W01	89°	1–16 mm
W01 B5	Wagner W01	89°	16–20 mm
Z5.1 SCMT89	ISO SCMT09T3	89°	1–16 mm
Z5.1 CCGT90	ISO CCGT09T3 ISO CCMT09T3	90°	1–16 mm
Z5.1 SCMT45	ISO SCMT09T3	45°	2–25 mm (Chamfering)

Shank-Ø D mm (inch)	d mm	d ₁	L mm	L ₁ mm	L ₂ mm	L ₃ mm
16	10.2	R1/8"	46	58	47.5	47.5
19.05 (3/4")	12.2	R1/8"	46	58	47.5	47.5
20	12.2	R1/8"	46	58	47.5	47.5
25	17	R3/8"	50	62	46	46
25.4 (1")	17	R1/8"	56	68	54.5	54.5
28.5	10	R1/2"	80	92	62	62
40	16.2	M6	120	132	57.5	57.5
VDI20	16.5	–	40	71.5	77	–
VDI25	16.2	–	48	82.5	87.5	–
VDI30	16.2	–	55	82.5	87.5	–
VDI40	20.2	–	63	134.5	87.5	–

Special shanks on request



Multi-cutter Turning System MSD20R

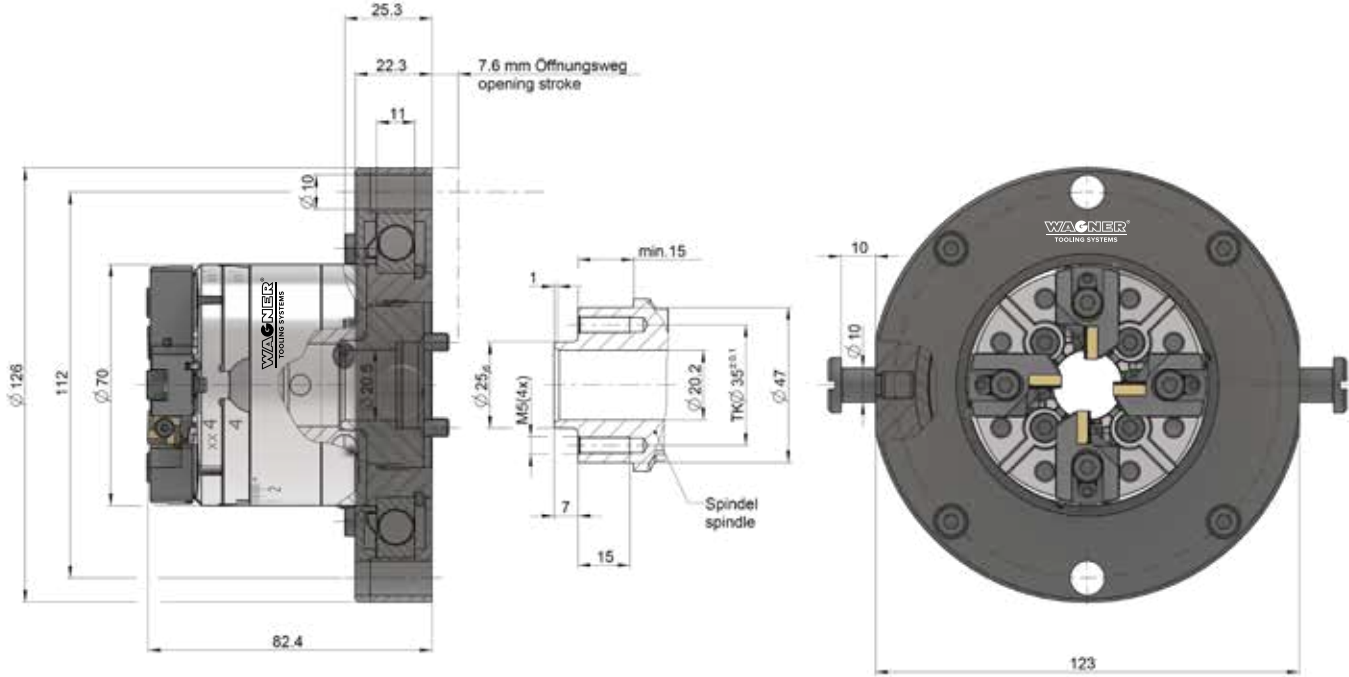

Insert holders	Cutting inserts	Cutting edge position	Working range
W01 B5	Wagner W01	89°	1–16 mm
W02 B5	Wagner W02	89°	16–20 mm
Z5.1 SCMT89	ISO SCMT09T3	89°	1–16 mm
Z5.1 CCGT90	ISO CCGT09T3	90°	1–16 mm

Accessories:

Special shanks on request

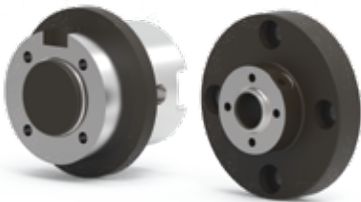



Multi-cutter Turning System MSD30

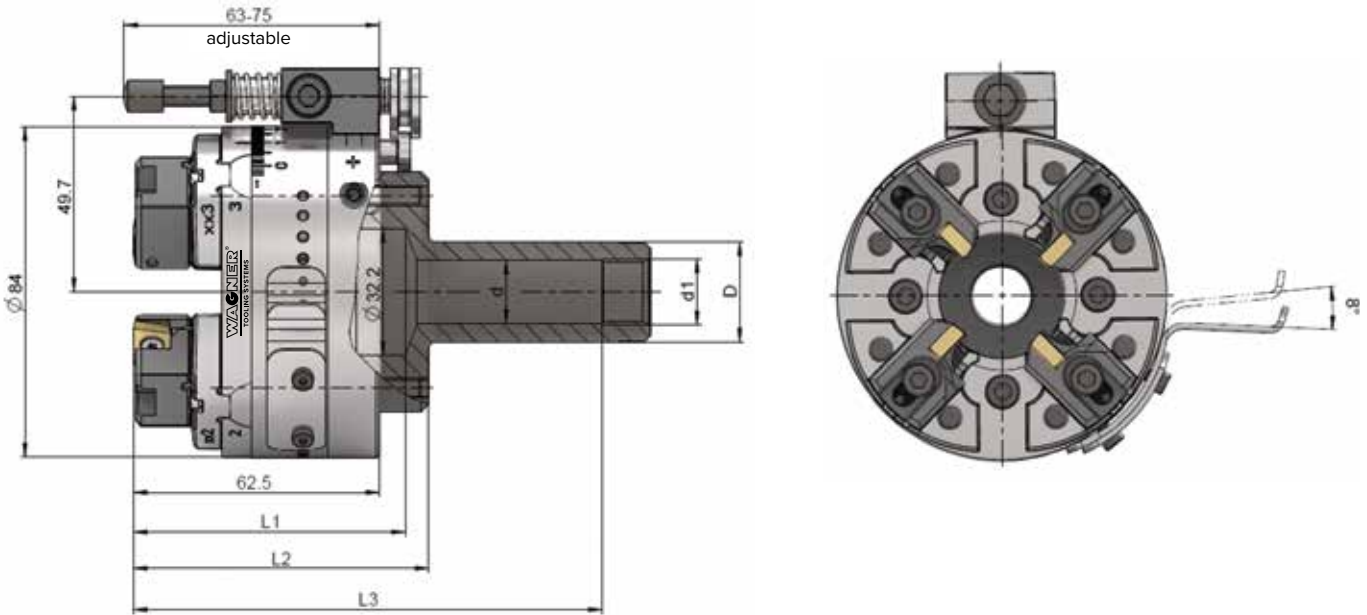

Insert holders	Cutting inserts	Cutting edge position	Working range
W01 B5.0	Wagner W01	89°	16–30 mm
Z5.1 SCMT89	ISO SCMT09T3	89°	16–30 mm
Z5.1 CCGT90	ISO CCGT09T3 ISO CCMT09T3	90°	16–30 mm
Z5.1 SCMT45	ISO SCMT09T3	45°	16–35 mm (Chamfering)

Shank-Ø D mm (inch)	d mm	d ₁	L mm	L ₁ mm	L ₂ mm	L ₃ mm
25	16	R3/8"	56	68	74	118
25.4 (1")	16	R1/8"	56	68	74	118
30	21	R1/2"	63	68	74	125
40	32	R1/2"	120	–	74	182
50	32	R1/2"	120	–	74	182
VDI30	16,2	–	55	–	88	82



Multi-cutter Turning System MSD30R

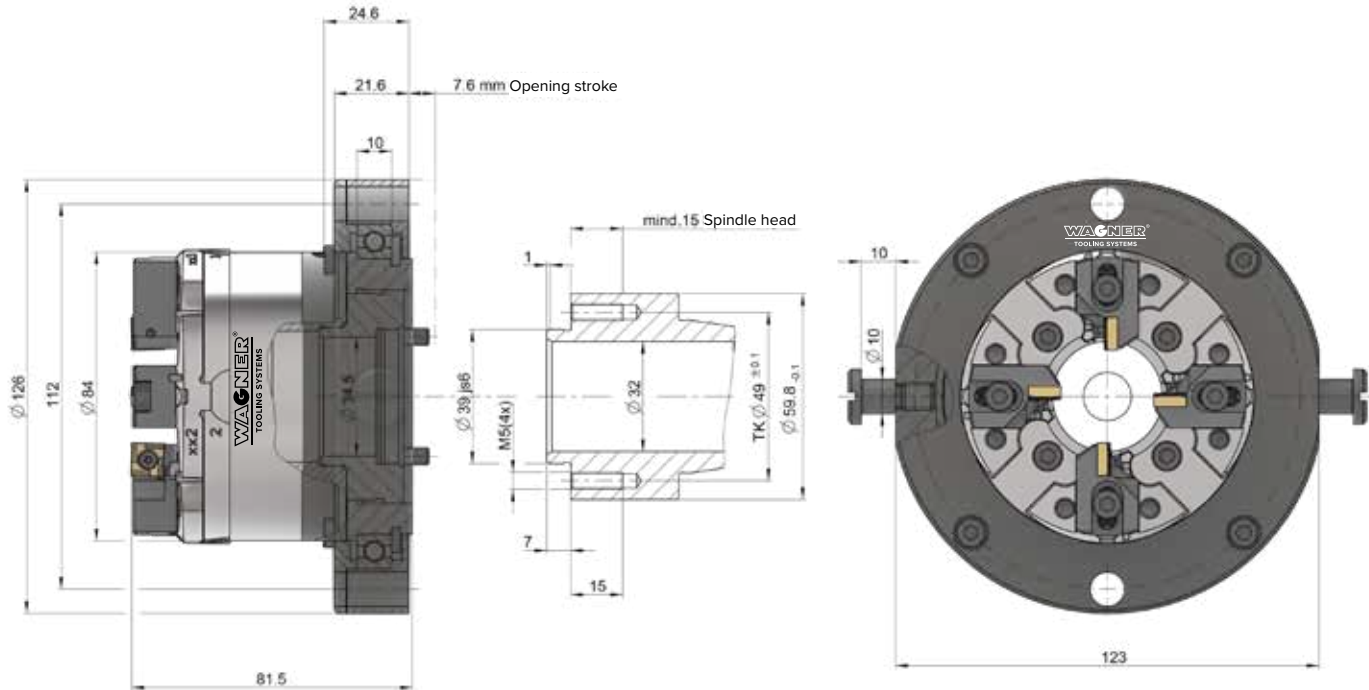

Insert holders	Cutting inserts	Cutting edge position	Working range
W01 B5.0	Wagner W01	89°	16–30 mm
Z5.1 SCMT89	ISO SCMT09T3	89°	16–30 mm
Z5.1 CCGT90	ISO CCGT09T3 ISO CCMT09T3	90°	16–30 mm
Z5.1 SCMT45	ISO SCMT09T3	45°	16–35 mm (Chamfering)

Accessories:

Special shanks on request

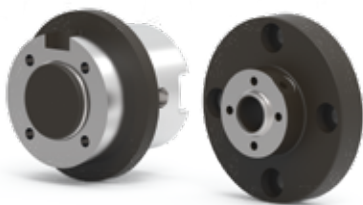



Multi-cutter Turning System DSD12

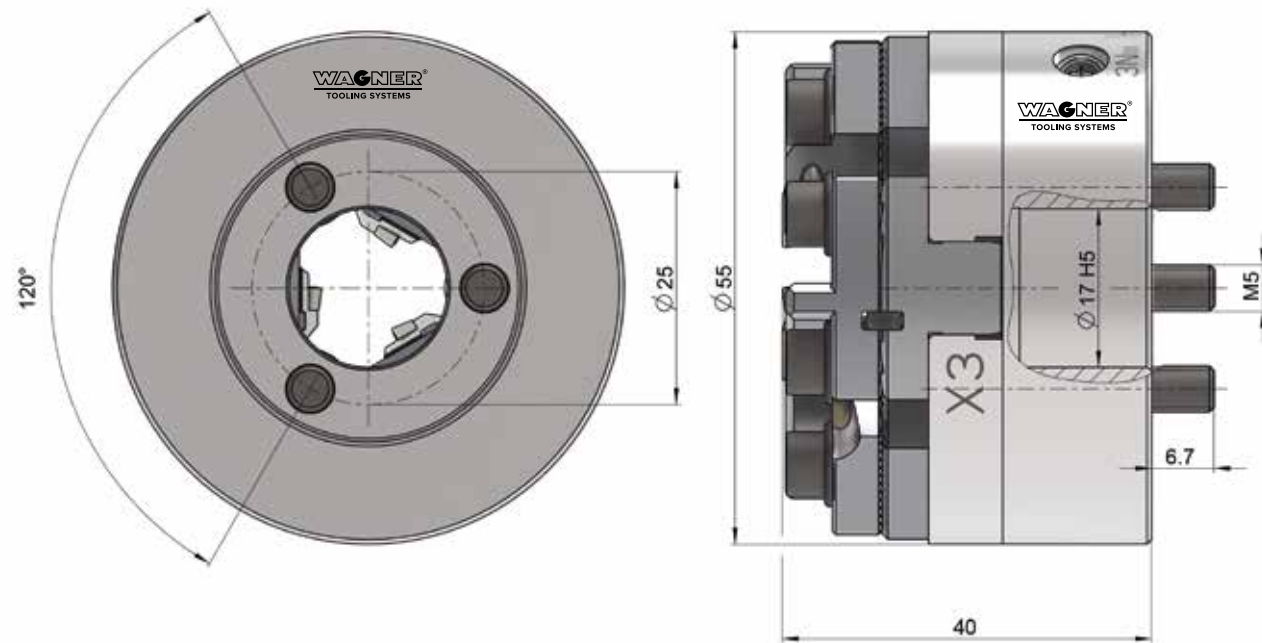

Insert holders	Cutting inserts	Cutting edge position	Working range
Z5.0 SCMT90	ISO SCMT0602	90°	1–12 mm

Figure: Shank dimensions see table

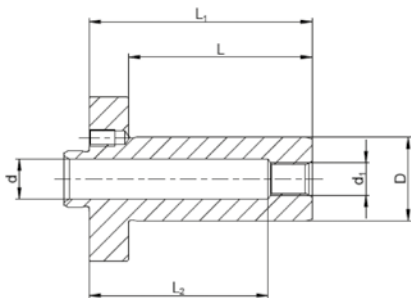

Shank-Ø D mm (inch)	d mm	d ₁	L mm	L ₁ mm	L ₂ mm
12	5	M6	34	46	38
16	7	G1/8"	48	60	48
19.05 (3/4")	12.2	G1/8"	46	58	47.5
20	12.2	G1/8"	46	58	47.5
22	12.2	G1/8"	46	58	47.5
25.4 (1")	12.2	G1/8"	56	68	54.5
Special shanks on request					



Multi-cutter Turning System DSD16

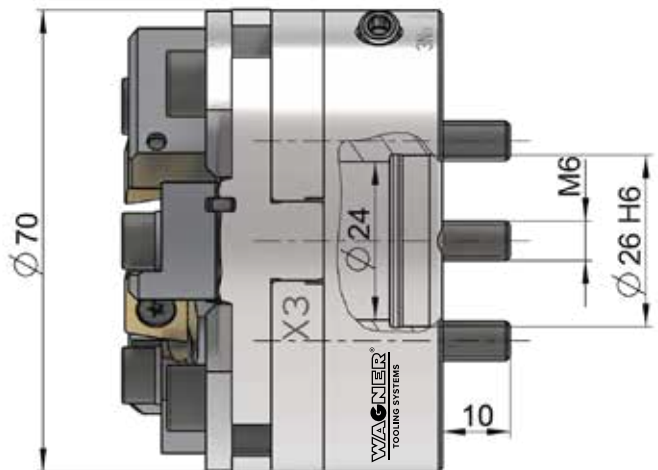
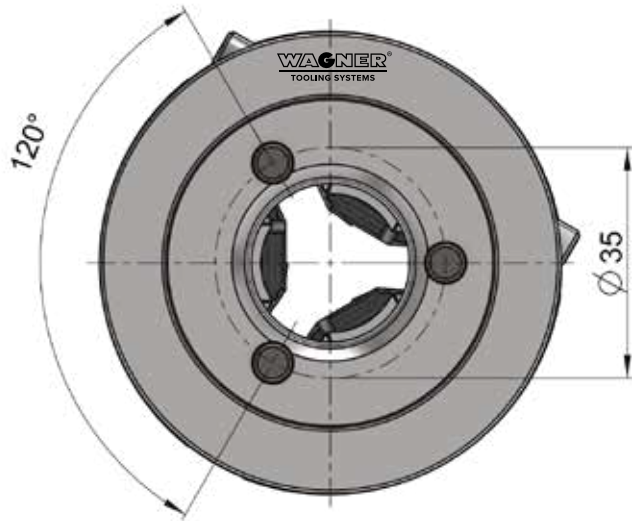

Insert holders	Cutting inserts	Cutting edge position	Working range
W01 B5.0	Wagner W01	89°	1–16 mm
Z5.0 SCMT90	ISO SCMT09T3	89°	1–16 mm
Z5.0 CCGT90	ISO CCMT09T3	90°	1–16 mm
Z5.0 SCMT45	ISO SCMT09T3	45°	2–25 mm (Chamfering)
Z5.0 TCMT16-30	ISO TCMT16T3	30°	2–30 mm (Chamfering)

Figure: Shank dimensions see table

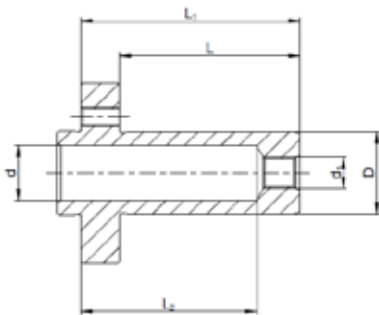

Shank-Ø D mm (inch)	d mm	d ₁	L mm	L ₁ mm	L ₂ mm
16	10,2	R1/8"	46	58	47,5
19.05 (3/4")	12,2	R1/8"	46	58	47,5
20	12,2	R1/8"	46	58	47,5
25	17	R3/8"	50	62	46
25.4 (1")	17	R1/8"	56	68	54,5
35	10	R1/2"	80	92	62
40	16.2	M6	120	132	57,5
VDI20	16.5	–	40	55	14,5
VDI25	16.2	–	48	65	22,5
VDI30	16.2	–	55	72	57,5
Special shanks on request					