

Thread Cutting Heads

Large Heads for heaviest metal-cutting processes



Thread Cutting with success

GEWE

For heavy metal-cutting

For big thread diametres

Controllable with an outlet device

Easy to operate and to change the tools

Free removal of cuttings

Long chasers you can regrind

Many types of threads

GEWE - S

For heavy metal-cutting

For big thread diametres

Controllable with an outlet device

Easy to operate and to change the tools

Free removal of cuttings

Long chasers you can regrind

Mainly pipe threads

Extremely fast due to an installed ball bearing





Thread Cutting Head



Thread Rolling Head



Thread Rolling Attachment

Cutting large external threads

Dear reader,

WAGNER® Tool Systems is your competent partner for the production of external threads. Only we are your competent partner providing all production processes from one source when dealing with thread rolling attachment, thread rolling head and the thread cutting head.

We offer you even more: for your heaviest cutting processes we have developed our large head type GEWE and GEWE-S. On the following pages you will find more details about its extraordinary performances.

Are you interested in our other production processes? Please ask for more information.
We look forward to hearing from you.

Yours sincerely,



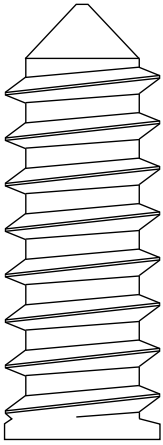

Wood Threads

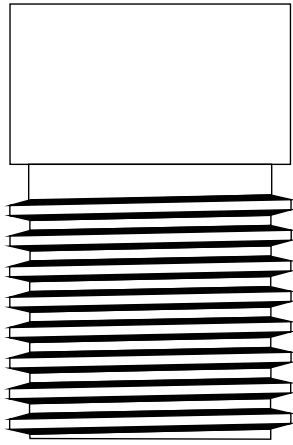

Trapezoid Threads



The GEWE-S Head at work

Application Areas

These thread cutting heads are designed and highly-precise manufactured to perform most heaviest metal- cutting processes. They cut external threads precisely in a diameter from 9 to 175 mm or pipe threads from 3 to 8 inches. Mainly gas- and water pipes which are used all over the world possess these large external threads. However, this large thread cutting head performs extremely well when cutting trapezoid- and round threads or regular threads.

Installation Sizes

We distinguish between 2 types, the GEWE and the GEWE model S. Both of them we call: the Large Heads.

These large heads are produced in 3 installation sizes with 9 different types with different cutting ranges. You have the choice: it only depends which diameter or which type of thread you would like to cut.

Models

The model complies with the type of thread, the work piece or your machine tool. The GEWE head can be installed either rotary or stationary. The GEWE-S head is always installed rotary.

Manufactured Individually

Our large heads don't meet your expectations? That is not a problem for us! We can produce your individual cutting head.

Long Service Life

Our large heads are designed for an extremely long service life. The parts left to abrasion such as gliding pieces, eccentric ring, holder device and head plate are specially hardened and ground. All abrasive parts can be replaced quick and easy.



Setting the chaser in the chaser holder with the help of the setting device.



Trapezoid Thread

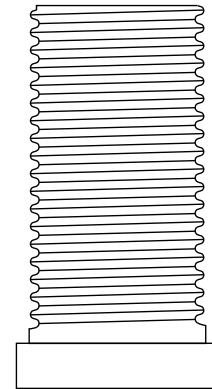

Round Thread

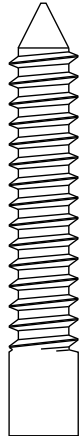

Wood Thread

Easy to Operate

In order to convert to other types of threads or diameters chaser holder and chaser can be replaced easily: just pull back the guide ring, swing the chaser holder out of the holder device and pull it out. You may change the tools in less than one minute.

The chaser holders can be preset and guarantee short setting times. In a setting device the chaser in the chaser holder is adjusted in its accurate fixed position. Therefore the set values are given and are to be set by means of a setting gauge and a dial indicator. Even the adjustment of the thread diameter is quick and easy and can be done alone easily:

it can be set precisely on a scale by continuously turning the excentric ring in the excentric casing.

Control

Once the thread is cut, the head is opened and the return motion begins. That's the big advantage the work piece runs back without touching the chasers. Thus the quality of the thread improves and the secondary processing time is reduced.

Both opening and closing of the thread cutting head is done by the attachment ring. It either works via hydraulic cylinders or via stops.

Made in Pliezhausen

All the elements of our thread cutting heads are manufactured individually by qualified staff at our modern company in Pliezhausen. Then the parts are assembled individually by hand and individually tested in operation. In an individual fine tuning the holding devices are ground in mechanically, thereupon the holders almost run free from clearance. WAGNER® herewith offers you a tool of high quality for an excellent performance.



A rule says:
the longer the
first cut,
the better the
surface of the
thread and the
service life of
the chasers.

The WAGNER® chaser grinding fixture with fixed chaser



The WAGNER® chasers in the first cut long, medium and short

WAGNER® Chasers

The thread cutting heads type GEWE are thus constructed so that long chasers may be used. The thread profile of the WAGNER®-chasers covers the whole length of the chasers which means a high operating efficiency.

The chasers of a chaser set may vary in their length. You can regrind and reuse them until they are almost used up. WAGNER® chasers are manufactured from HSS (High Speed Steel). An automatic special- hardening treatment produces even and tough chasers for a high cutting performance.

We recommend changing the chasers at an early stage so that you may not have to regrind them much. The basic equipment for regrinding the chasers is a WAGNER® chaser grinding fixture.

The cutting- and grinding angles are easy to set according to the information in the tables. The angles can be set exactly when they are put up on a tool grinding machine. The cutting angle has like every non-cutting process to be matched with the cutting material, the lubricant, the coolant and the necessary cutting speed.

You can purchase a complete chaser grinding machine at WAGNER® Werkzeuge.

Free Removal of Cuttings

Due to the favourable arrangement of the chasers at the WAGNER® thread cutting head the cuttings flow off freely. The cutting process won't be hindered as well as the cut threads won't be spoiled. pieces with short

Chaser First Cuts

There are several first cuts for chasers:
the long first cut, for work pieces made of rolled material or with outside the medium first cut for work pieces without outside, blank or pre- turned parts and the short first cut for work pieces with short thread outlets or threads against the collar.

Furthermore we offer you custom-made first cuts and first cuts with an additive chamfer (also called nipple first cuts).

Two Cuttings

In the following cases two cuttings are necessary: with highly lead threads and deeply cut threads as with work pieces with outside and hard materials. By using graded sliding pieces the two cuttings can be made directly one after another so that a mandrel stop may not be necessary.

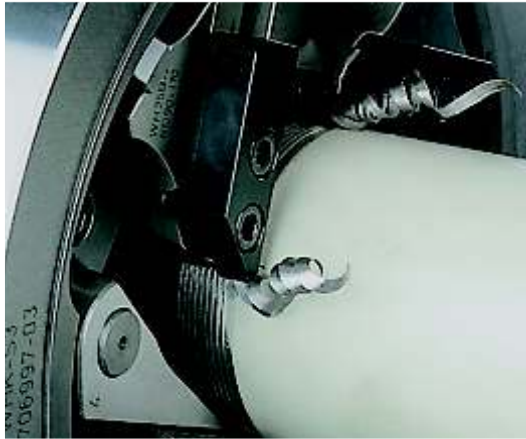

Free removal of the cuttings

Each GEWE head made by WAGNER® also cuts **left-handed threads**. Therefore the holder guides, the chaser holders and the chasers have to be replaced.

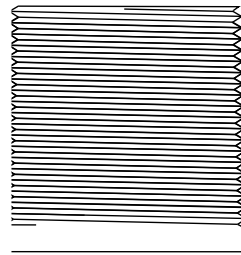

Left-handed thread
(conical pipe nipple)

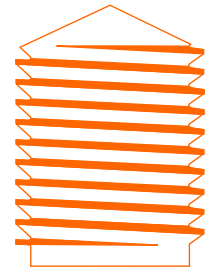

Left-handed thread
(buttress thread)

Type GEWE

The different installation sizes of the type GEWE can be built on to various types of tool machines. Such as pipe- and pipe end cutting machines, turning machines or special purpose machines.

Types of Threads

You can cut numerous types of threads with the large head type GEWE:

Metric regular threads DIN 13

Metric fine threads DIN 13

Whitworth threads

UN threads

Whitworth pipe threads

NPT threads

Trapezoid- and round threads

Buttress threads

Conical Threads

Conical threads are to be cut continuously with conical chasers. For each taper a conical excentric ring and the appropriate number of conical chasers holder- sliding pieces are necessary. With chaser holder and excentric ring for cylindrical threads conical threads are to be cut to the width of chasers by using special conical chasers.

Cutting Ranges

Type	Metric regular thread DIN 13	Metric fine thread DIN 13	Whitworth / UN thread	Whitworth pipe thread	NPT thread	Trapezoid- and pipe thread
WDK	M8 - M52	Ø8 - Ø88 (Ø112)	3/8" - 2"	R 1/4" - R 2"	1/4" - 2"	Ø10 - Ø44
WEK	M8 - M52	Ø8 - Ø88 (Ø112)	3/8" - 2"	R 1/4" - R 3"	1/4" - 3"	Ø10 - Ø44
WGK	M12 - M76	Ø12 - Ø110 (Ø160)	1/2" - 3"	R 1/2" - R 3"	1/2" - 3"	Ø12 - Ø62
WHK	M12 - M76	Ø12 - Ø110 (Ø160)	1/2" - 3"	R 1/2" - R 4"	1/2" - 4"	Ø12 - Ø62
WJK	M24 - M100	Ø24 - Ø160 (Ø214)	1" - 4"	R 1" - R 4"	1" - 4"	Ø24 - Ø90
WKK	M24 - M100	Ø24 - Ø160 (Ø214)	1" - 4"	R 1" - R 6"	1" - 6"	Ø24 - Ø90

Measurements in mm

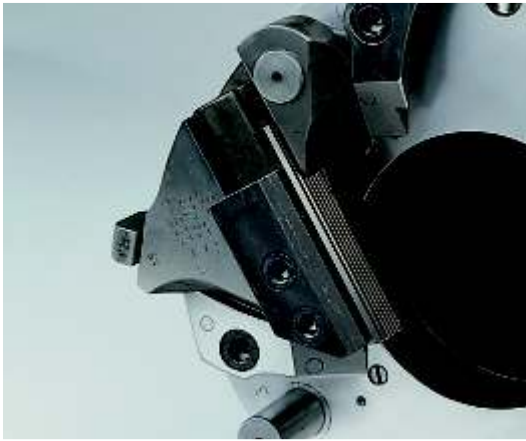

Chaser holder with chaser

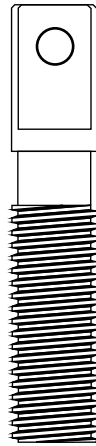

Two- or multi-start thread

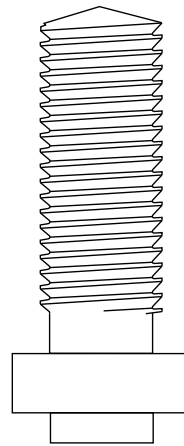

Buttress thread

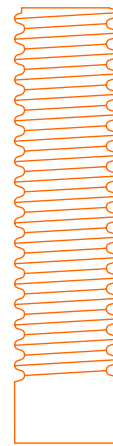

Round thread

Type GEWE

Side view

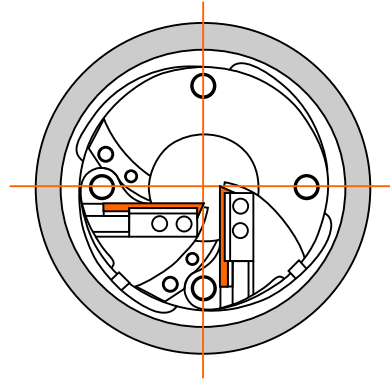
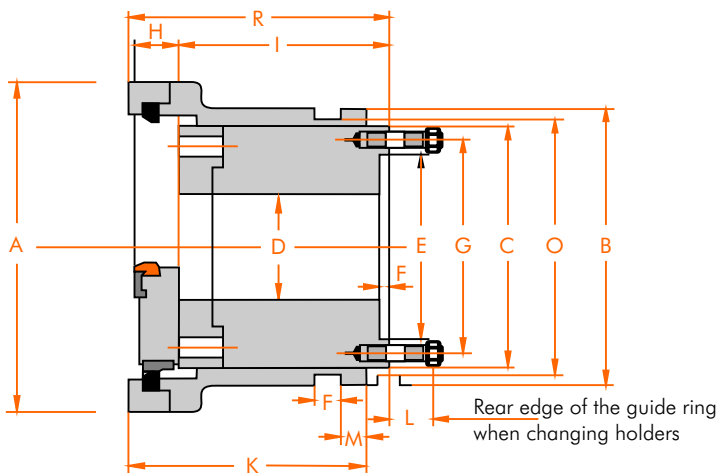

Building sizes

Type	A	B	C	D	E (H7)	F	G	H max.	I	K	L	M	N (H7)	O (-0,15)	P (4 St.)	R max.
WDK	310	260	220	65	170	10	195	77	190	208	31	25	25	240	M 12	252
WEK	310	260	220	95	170	10	195	77	190	208	31	25	25	240	M 12	252
WGK	370	310	270	95	220	10	240	90	220	243	36	25	30	290	M 16	290
WHK	370	310	270	120	220	10	240	90	220	243	36	25	30	290	M 16	282
WJK	410	340	300	120	250	10	270	80	240	263	36	20	40	320	M 16	294
WKK	410	340	300	175	250	10	270	80	240	263	36	20	40	320	M 16	300

Measurements in mm

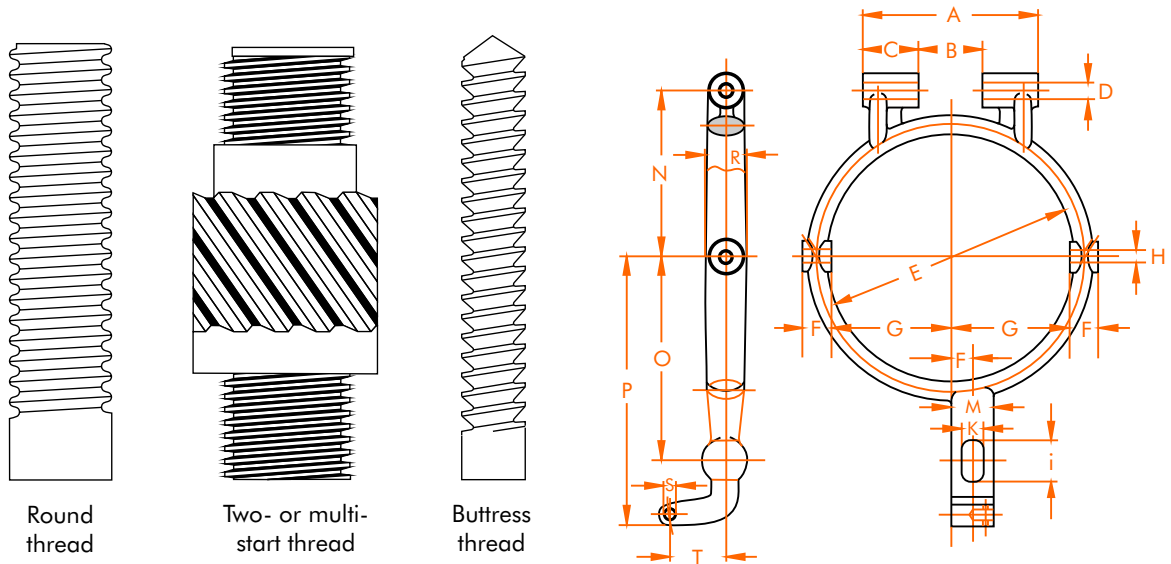

Type GEWE

Building sizes of the attachment rings

Type	A	B	C	D	E	F	G	H	I	K	L	M	N	O	P	R	S	T
WDK	180	40	100	20	284	30	135.5	16	25	25	50	50	186	209	286.5	50	10	70
WEK	180	40	100	20	284	30	135.5	16	25	25	50	50	186	209	286.5	50	10	70
WGK	255	77.5	100	25	340	40	160.5	20	30	30	60	60	216	254	339	60	10	80
WHK	255	77.5	100	25	340	40	160.5	20	30	30	60	60	216	254	339	60	10	80
WJK	255	77.5	100	25	370	40	175.5	20	35	30	60	60	247	303	398	65	13	80
WKK	255	77.5	100	25	370	40	175.5	20	35	30	60	60	247	303	398	65	13	80

Measurements in mm

Weights

Type	Cutting Head in kg	Set of chasers in kg	Setting device in kg	Set of chasers, in kg			Number of chaser holders in the head
				25x12x100	40x16x90	55x20x100	
WDK	50	7	1,6	0.75	1.65	2.7	4
WEK	50	7	1,6	0.75	1.65	2.7	4
WGK	90	11	2,1	0.75	1.65	2.7	4
WHK	90	11	2,1	0.75	1.65	2.7	4
WJK	140	14	2,3	0.75	1.65	2.7	5
WKK	140	14	2,3	0.75	1.65	2.7	5



Guide ring with excentric casing and ball bearing self-locking collar of the type GEWE-S



Headbody with holder device, flange plate and chaser holder of the type GEWE-S

Type GEWE Model S

The different installation sizes of the type GEWE-S are individually designed for machine tools with fast spinning mandrels. This is necessary for instance for pipe-thread-cutting machines with a high cutting tempo.

A brake mechanism prevents the early opening of the head with high axial tempos.

Conical Threads

Conical threads are to be cut continuously with conical chasers.

In order to cut conical threads with direct control the excentric ring is widened.

For each taper a conical excentric ring and the appropriate number of conical chaser holder-sliding pieces is necessary.

Ball Bearing

The operation ring for opening and closing of the cutting head is kept in a ball bearing.

Types of Threads

The large head GEWE model S has been build especially to cut Whitworth pipe threads and NPT threads.

May we help you with anything else? Please don't hesitate to phone us. We look forward to solving your problems.

Cutting ranges

Type	Whitworth Pipe threads	NPT threads	Length in mm, with conical threads (max.)
WEK - S8	R 1/4" - R 3"	1/4" - 3"	44
WHK - S3	R 1/2" - R 4"	1/2" - 4"	63
WKK - S2	R 1" - R 6" (R 8")	1" - 6"	57



The cutting head GEWE model S

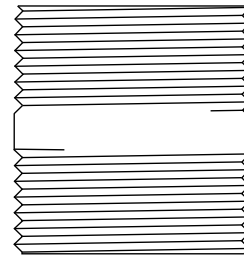

Cylindrical
Double-Pipe nipple

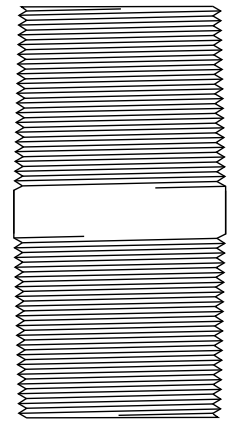

Conical
Double-Pipe nipple

Type GEWE Model S

Weights

Type	Cutting head in kg	Set of chaser holders in kg	Setting device in kg	Set of chasers, in kg			Number of chaser holders in the head
				25x12x100	40x16x90	55x20x100	
WEK-S8	80	7	1.6	0.75	1.65	2.7	4
WHK-S3	108	11	2.1	0.75	1.65	2.7	4
WKK-S2	135	14	2.3	0.75	1.65	2.7	5

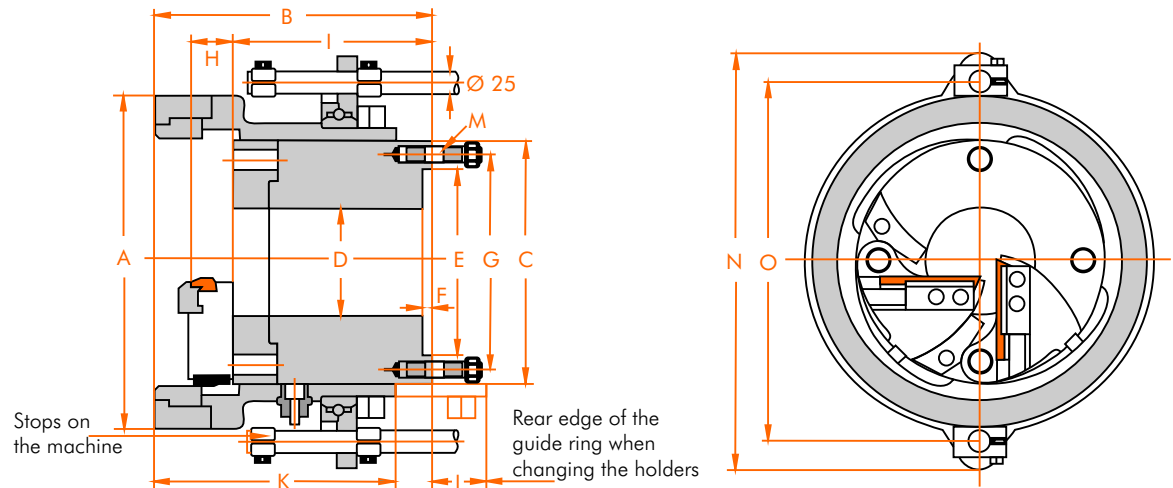

Building sizes

Type	A	B	C	D	E	F	G	H	I	K	L	M	N	O
WEK - S8	310	257	220	95	170	10	195	67	190	226	80	M 12	460	400
WDK - S3	370	306	270	120	220	10	240	48	220	267	99	M 16	460	400
WKK - S2	410	322	300	175	250	10	270	77	240	285	100	M 16	510	450

Measurements in mm

Ways of application for thread cutting heads

Thread cutting head rotary

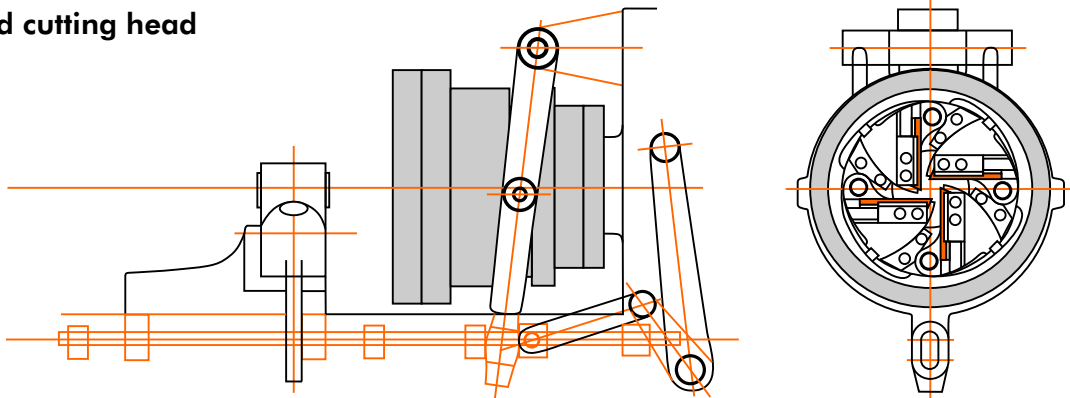

Used on thread cutting machines or turning machines.
The bearing of the attachment ring is to be build on to the head stock.

Thread cutting head rotary

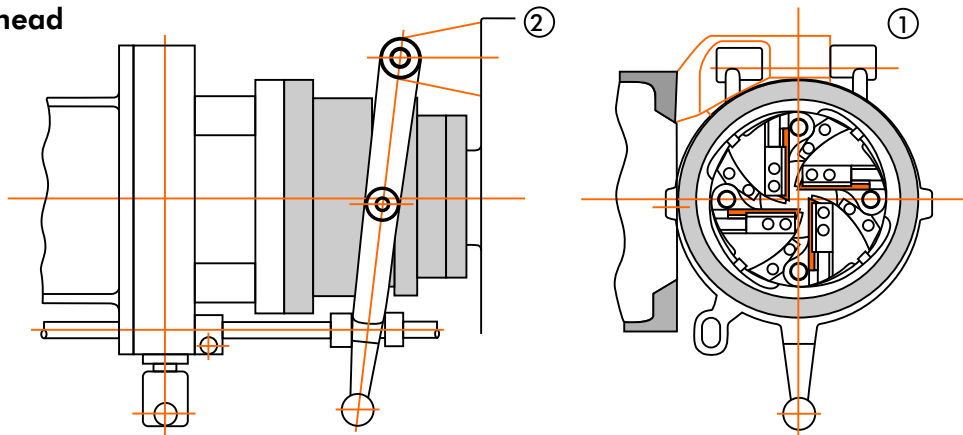

Used on thread cutting machines or turning machines.
The bearing of the attachment ring is fixed on: ① the cheek or ② on the head stock.

Thread cutting head stationary

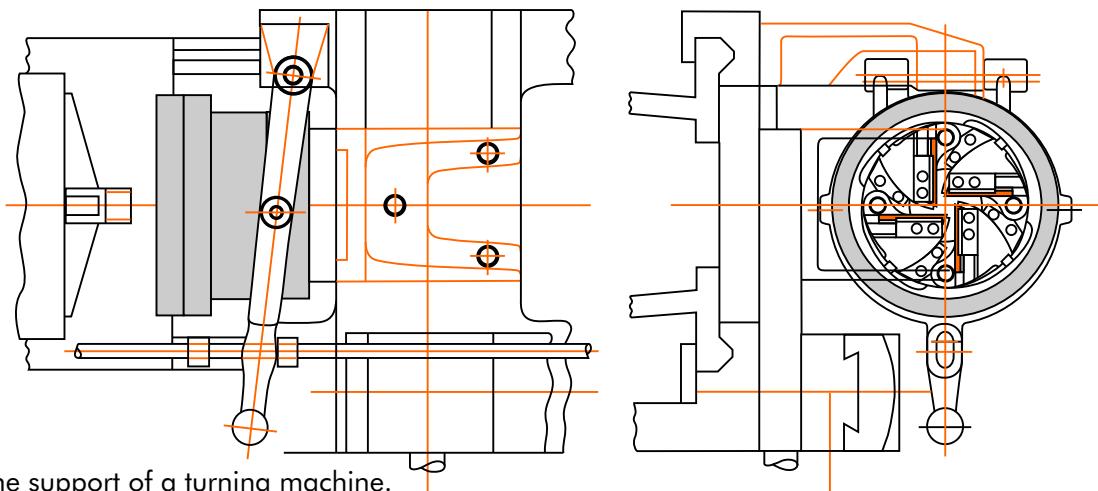

On the support of a turning machine.

Answers to Frequently Asked Questions

The Customer asks:

- Are the components produced in **various types**?
- How is the head build on to the machine?
- How does **the control** of the thread cutting head work?
- Can the thread cutting head be used in **continuous duty**?
- Are there different **chaser qualities**?
- Is there a WAGNER® **on-site-service**?

The Producer answers:

Yes, chaser holders and chasers are produced accordingly to the threads that need to be cut.

GEWE heads are flanged directly or via an adapter onto the mandrel.

Easily and directly. In the operating manual you may find operating suggestions and examples for use.

yes, WAGNER® developed the construction in 1896. Since then it was constantly improved and adjusted to the demands of the time. We guarantee that your cutting head will last you a very long time.

Yes, we offer optimal quality, depending on the material you would like to work on. We are awaiting your inquiries.

Yes, there is an area-wide field organisation.





Thread Cutting Head



Thread Rolling Head



Thread Rolling Attachment



Multi-Cutter Turning Head



Driven Tools Axial



Driven Tools Radial

WAGNER® - Tool Systems offers all the tools for metal machining!

Beside our thread cutting- large heads we offer you a wide range of tools for producing external threads such as the thread cutting heads in miniature- or normal size for exact, fast and good value threads.

The thread rolling heads for threads meant to be exact, fast, good value and even non-cutting. Or the also non-cutting thread rolling attachments for short threads with a very short outlet or with a thread behind the collar.

Another tool made by WAGNER® are the multi-cutter turning heads. With their four heavy metal-cutting edges they can turn more material than usual tools.

Our driven axial- or radial tools with their equipment complete our excellent range of tools.

With our wide range of products we recommend ourselves as your competent partner when dealing with metal machining.



Gutenbergstraße 4/1
D - 72124 Pliezhausen

Telefon (0 71 27) 97 33 00

Telefax (0 71 27) 97 33 90

info@wagner-werkzeug.de

www.wagner-werkzeug.de